

OPERATING AND MAINTENANCE INSTRUCTIONS
 (Read the entire sheet carefully and retain for future reference)



LADDER INSPECTION

- Upon receipt, inspect each unit immediately for damage incurred during shipping. If damage has occurred, sign for ladder as DAMAGED, contact the freight carrier and the manufacturer immediately. DO NOT USE LADDER.
- Inspect all ladders prior to each use, any ladders damaged or weakened from any cause SHALL NOT BE USED until repaired or replaced. Ladders damaged or worn beyond repair shall be destroyed. NEVER climb a damaged ladder.
- If assembly is required ensure all bracing is properly fitted.
- Ensure that all rubber tips are installed on all legs. Replace all tips that are worn.
- Check brake mechanism. All legs must rest firmly on the floor before climbing.
- Ensure all fasteners are properly tightened.
- Missing or worn labels must be replaced, please contact the manufacturer.

LADDER USE

- All employees shall be instructed by employer in the proper use of the unit, and shall read the operating instructions before being allowed to use any unit.
- Employees must read and obey all instruction labels attached to the unit.
- Units must not be loaded beyond the weight marked on the label.
- The user shall face the ladder and use the handrail when ascending or descending. Overreaching while on a unit could cause instability and result in a fall.
- Additional height shall not be gained by the addition of any type of extension or object being placed on the unit.
- Do not stand on railing or top guardrail. The user shall not ascend farther than the top step.
- Foreign material such as grease shall be removed from shoes prior to ascent of a unit.
- Access to or egress from any step or platform from any other elevated surface shall be prohibited unless the unit has been positively secured against any movement.
- DO NOT USE ladder when occupied.
- DO NOT USE near open electrical circuits, contact with an energized circuit or conductor will cause an electrical shock.
- DO NOT USE in front of a door unless the door is secured in an open position, locked or guarded.
- DO NOT USE on an uneven or sloping surface, units are to be used on a flat level surface.
- DO NOT USE if you tire easily, are subject to fainting spells, use medicine, alcohol, or are physically handicapped.

Mobile Ladder Stand Assembly Instructions
 for 8-15 step Safety Angle (EC) models

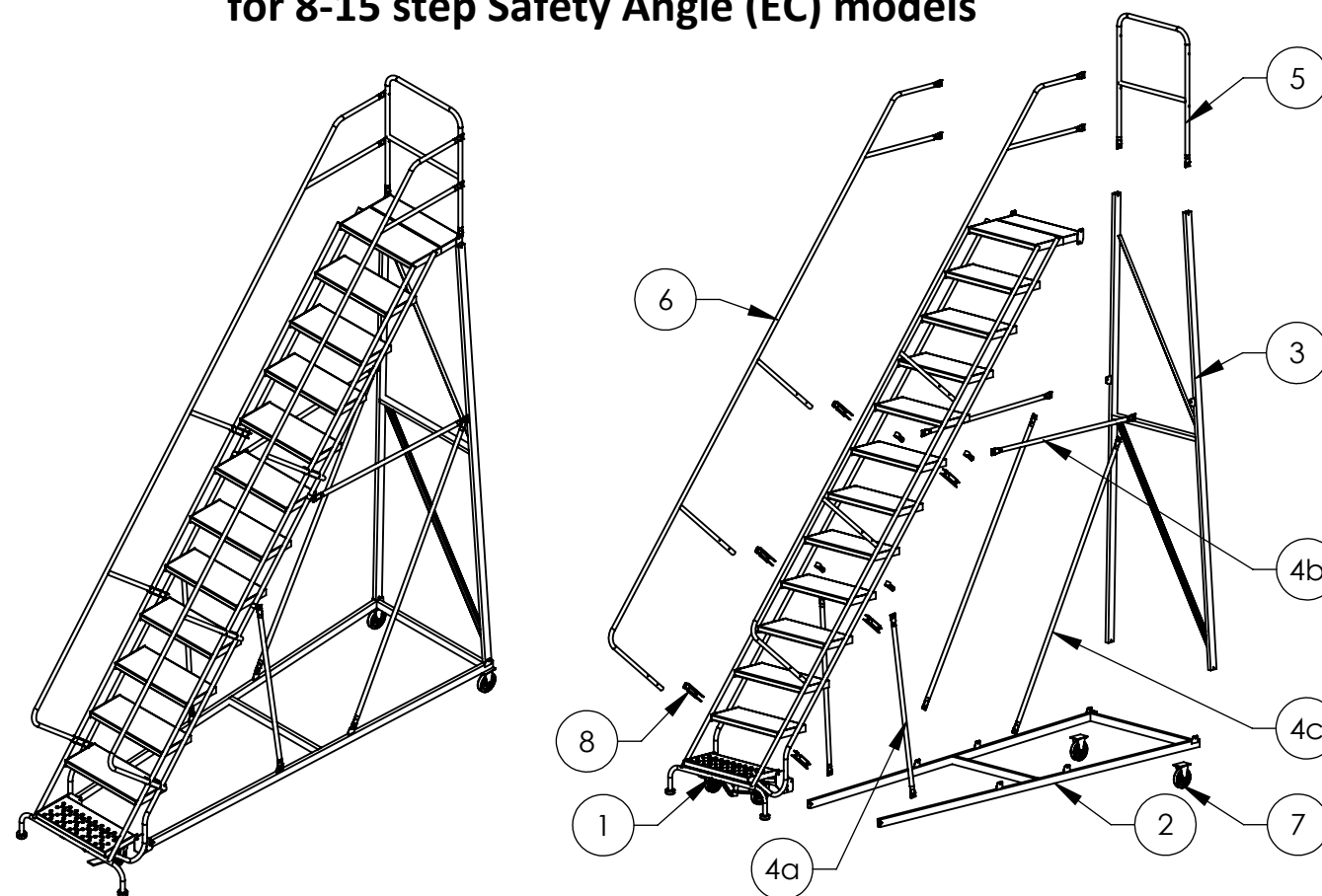

COMPONENTS				
PART #	8 Step	9-11 STEP	12-15 STEP	DESCRIPTION
1	1	1	1	STRINGER ASSEMBLY (ATTACHED)
2	1	1	1	BOTTOM ASSEMBLY (ATTACHED)
3	1	1	1	BACK ASSEMBLY (ATTACHED)
4a	2	2	2	SUPPORT TUBE A
4b	0	2	2	SUPPORT TUBE B
4c	0	0	2	SUPPORT TUBE C
5	1	1	1	GUARDRAIL
6	2	2	2	HANDRAIL
7	2	2	2	CASTERS
8	4	4	6	HANDRAIL CLAMP
9	2	4	4	SUPPORT TUBE CLAMP
	1	1	1	FASTENER PACK
	0	1	1	DOG LEG PACK



800-565-2165
 www.tri-arc.com

LADDERS USED IN CALIFORNIA MUST BE EQUIPPED WITH CAL-OSHA KIT	
LADDER	CAL-OSHA KIT PART NUMBER
8-9 STEP LADDER	GRCAL0509
10-12 STEP LADDER	GRCAL1012
13-15 STEP LADDER	GRCAL1315

* TOOLS REQUIRED - UTILITY KNIFE, 1/2" SOCKET WRENCH, & OPEN END WRENCH

1. If you purchased a specialty ladder (ie Deep Top, All Directional, Stock Picking, etc.), be sure to read ALL instruction packets prior to any assembly.
2. Place the stringer on a firm working surface, laying on its side. The back and bottom assemblies ship fastened to the stringer but are folded flat.
3. Pivot the back and bottom assemblies until their connection holes align. Connect using 5/16" x 1-1/2" fasteners.

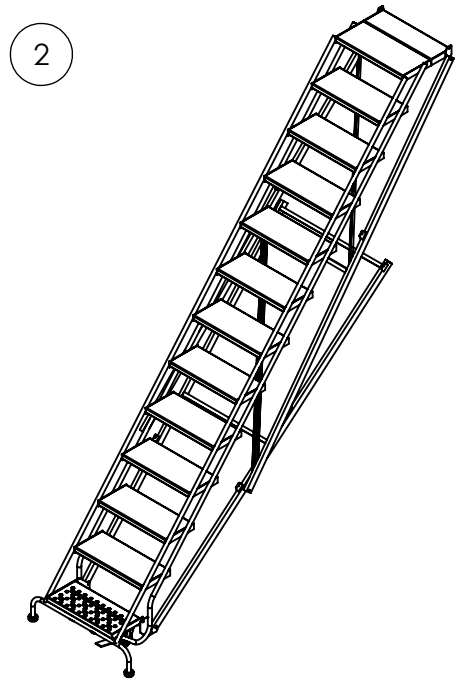

3

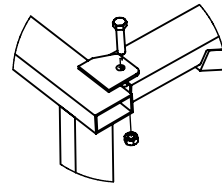

DETAIL A
SCALE 1 : 8

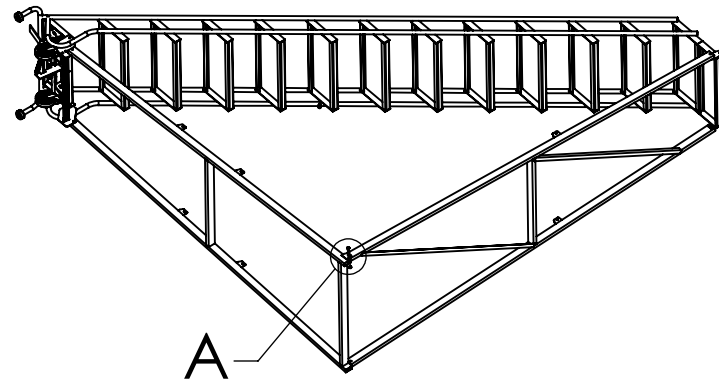

5. Attach casters to the bottom assembly using 5/16" x 1" fasteners.

5

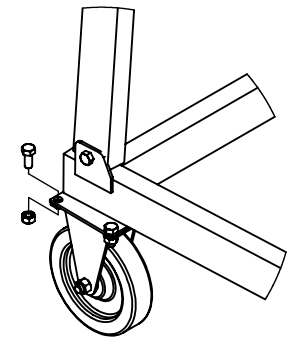

6. Attach the guardrail to the top of the stringer assembly using 5/16" x 1" fasteners.

6

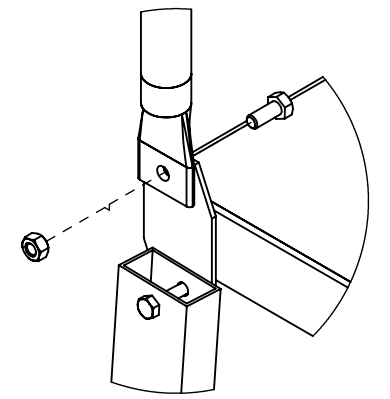

4. Install support tubes as shown below. Support tubes are connected to the support tube clamps using hand tightened 5/16" x 1" fasteners. Detailed figures below show examples of how the support tubes attach to the clamps.

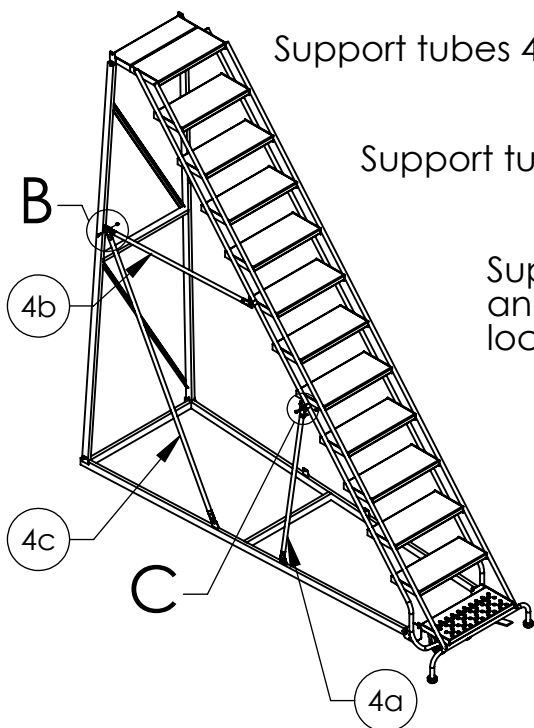

Support tubes 4a connect to the bottom and stringer.

Support tubes 4b (if provided) connect to the back and stringer.

Support tubes 4c (if provided) connect to the back and bottom. 15 step ladders have their own bolt location on the back assembly (not shown in picture).

4

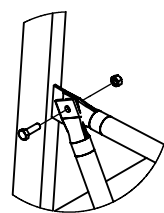

DETAIL B
SCALE 1 : 10

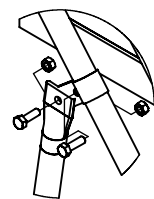

DETAIL C
SCALE 1 : 8

8

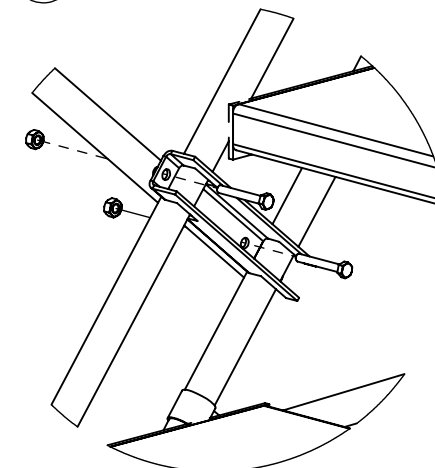

8. Attach the handrail posts to the stringer using handrail clamps and 5/16" x 1-3/4" fasteners as shown at the left.

9. Prior to standing the ladder upright, be sure to tighten all fasteners completely, including any that may have been only hand-tightened earlier.

7

