

ASSEMBLY INSTRUCTIONS FOR TAVS STABILIZER KIT

1. ADJUST PLATFORM TO DESIRED HEIGHT PER TAVS INSTRUCTIONS.
2. INSERT CONNECTOR TUBE NUTS (A) INTO PIPE (B) ENDS UNTIL JUST PAST FLUSH WITH END OF PIPE. SEE DETAIL G
3. BOLT PIPES TO LEGS AT LOWEST POSSIBLE HOLES AVAILABLE WITH SUPPLIED HARDWARE. BOLT (C), LOCK WASHER (D), AND WASHER (E).
4. TIGHTEN BOLTS BUT TAKE CARE NOT TO OVER TIGHTEN.

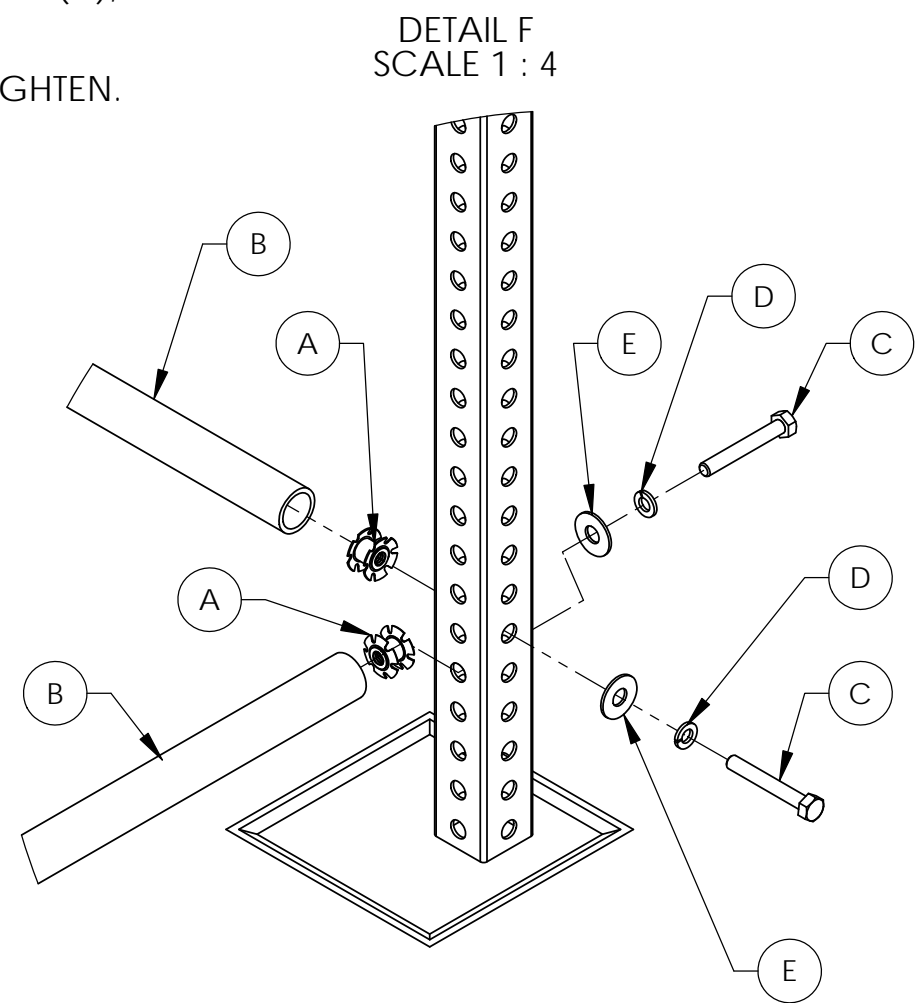
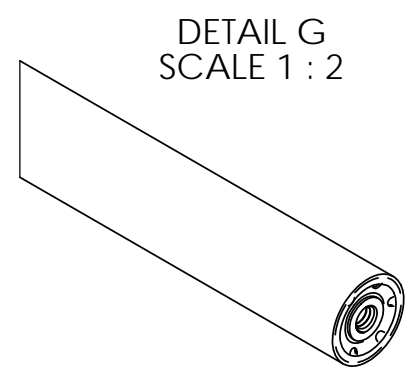
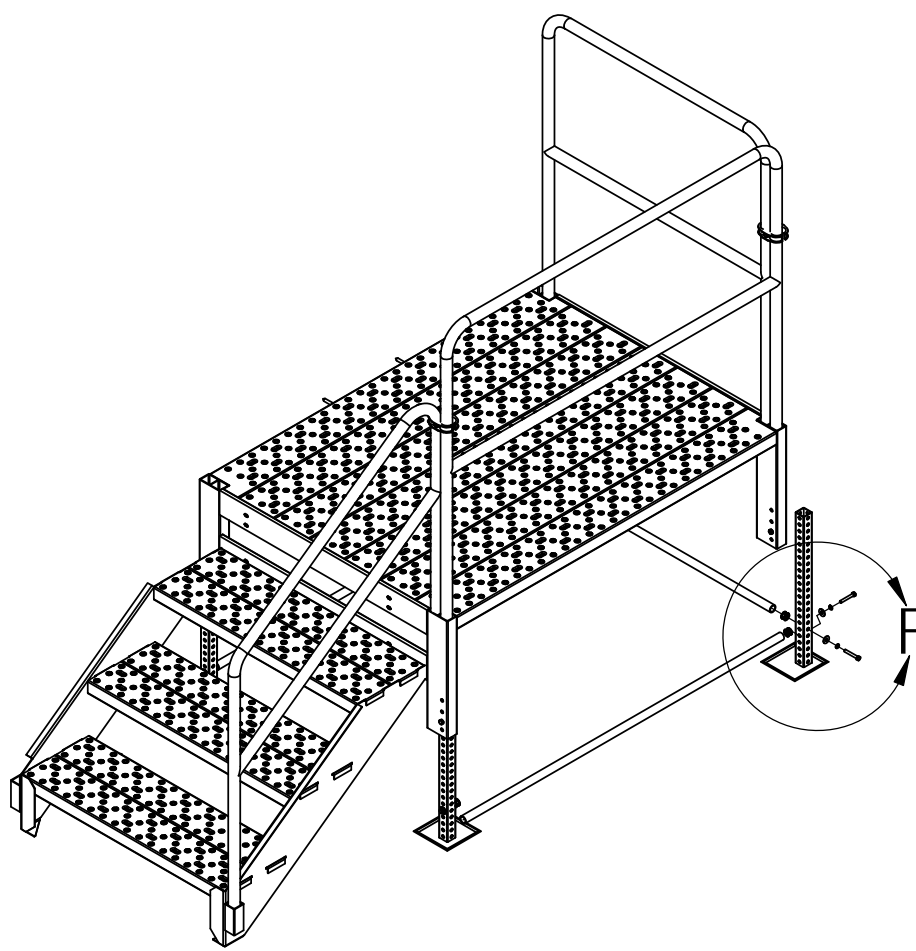
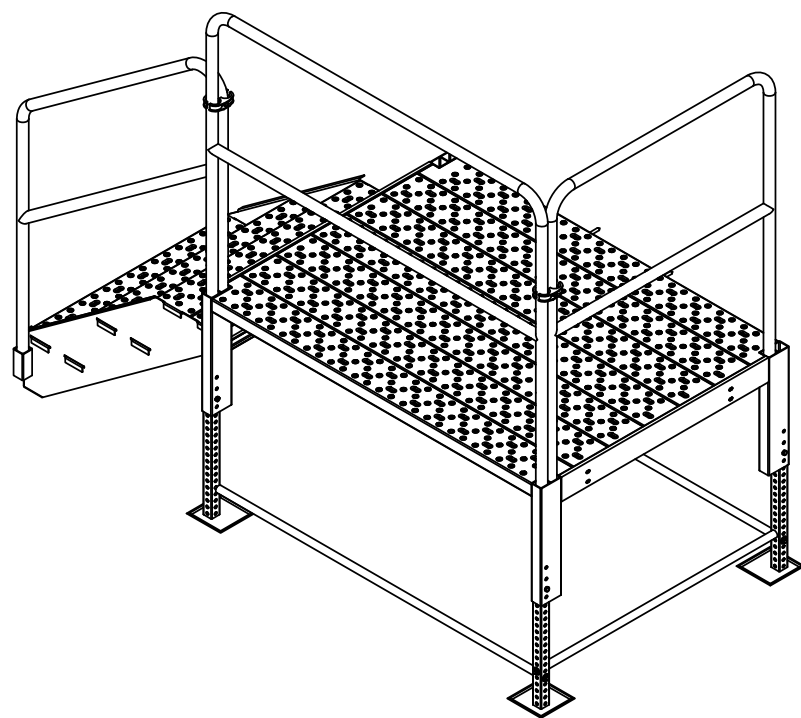

REVISION HISTORY: PROPRIETARY AND CONFIDENTIAL THE INFORMATION CONTAINED IN THIS DRAWING IS THE SOLE PROPERTY OF LINETT COMPANY, INC. ANY REPRODUCTION IN PART OR AS A WHOLE WITHOUT THE WRITTEN PERMISSION OF LINETT COMPANY, INC IS STRICTLY PROHIBITED.	UNLESS OTHERWISE SPECIFIED: DIMENSIONS ARE IN INCHES TOLERANCES: FRACTIONAL $\pm 1/16"$ ANGULAR: BEND ± 1 DEG.	NAME J.A.L.	DATE 11/6/14	LINETT COMPANY INC. TITLE: TAVSSK (TAVS STABILIZER KIT)
		DRAWN J.A.L.		
		CHECKED J.A.L.	11/6/14	
		ENG APPR. MFG APPR.		
		Q.A. COMMENTS:		
	MATERIAL ALUMINUM DO NOT SCALE DRAWING	SIZE B	DWG. NO. TAVSSK	REV 00
		SCALE: 1:24	WEIGHT: 10	SHEET 1 OF 1